

Service Manual

THE FISHER®

Consoles

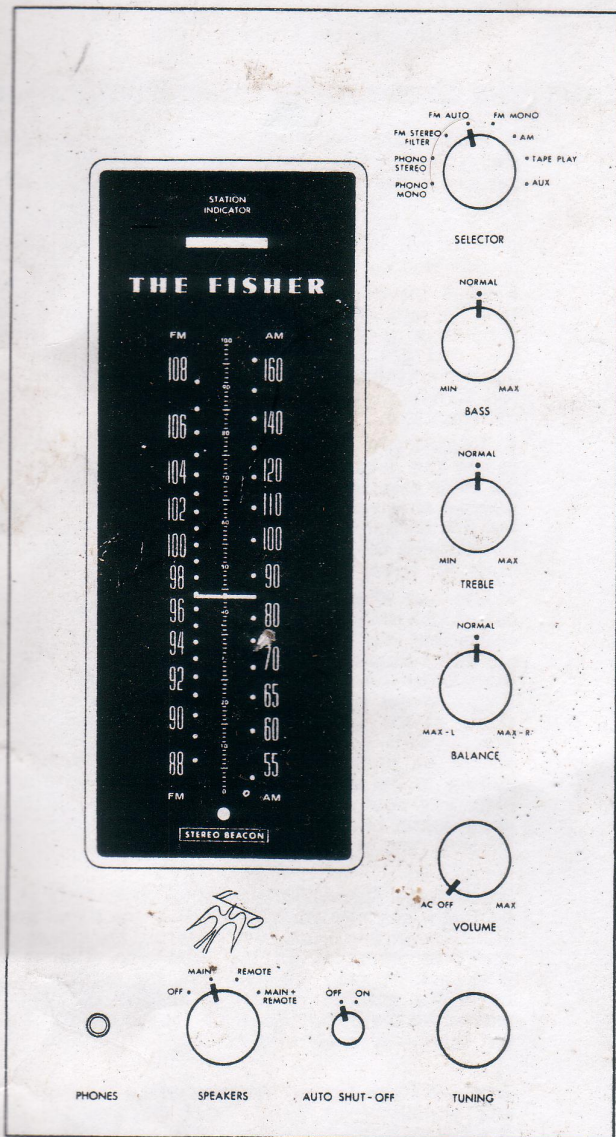

49A

AMPLIFIER

49T

TUNER

CAUTION: This is a FISHER precision high-fidelity instrument. It should be serviced only by qualified personnel — trained in the repair of transistor equipment and printed circuitry.

EQUIPMENT AND TOOLS NEEDED

The following are needed to completely test and align modern high-fidelity instruments such as amplifiers, tuners and receivers.

Test Instruments

Vacuum-Tube Volt-ohmmeter DC VTVM
Audio (AC) Vacuum-Tube Voltmeter (AC VTVM)
Oscilloscope (Flat to 100 kc minimum)
Audio (Sine-wave) Generator
Intermodulation Analyzer
Sweep (FM) Generator (88 to 108 mc)
Marker Generator
Multiplex Generator (preferably with RF output — FISHER Model 300 or equal).

Miscellaneous

Adjustable-Line-Voltage Transformer or line-voltage regulator
Load Resistors (2) — 8-ohm, 50-watt (or higher)
Stereo source (Turntable with stereo cartridge or Tape Deck)
Speakers (2) Full-range, for listening tests
Soldering iron (with small-diameter tip). Fully insulated from power line.

PRECAUTIONS

Many of the items below are included just as a reminder — they are normal procedures for experienced technicians. Shortcuts can be taken but often they cause additional damage — to transistors, circuit components or the printed-circuit board.

Soldering—A well-tinned, hot, clean soldering iron tip will make it easier to solder without damage to the printed-circuit board or the many many circuit components mounted on it. It is not the wattage of the iron that counts — it is the heat available at the tip. Low-wattage soldering irons will often take too long to heat a connection — pigtail leads will get too hot and damage the part. Too much heat, applied too long, will damage the printed-circuit board. Some 50-watt irons reach temperatures of 1,000° F — others will hardly melt solder. Small-diameter tips should be used for single solder connections — larger pyramid and chisel tips are needed for larger areas.

- When removing defective resistors, capacitors, etc., the leads should be cut as close to the body of the circuit component as possible. (If the part is not being returned for in-warranty factory replacement it may be cut in half — with diagonal-cutting pliers — to make removal easier.)
- Special de-soldering triplets are made for unsoldering multiple-terminal units like IF transformers and electrolytic capacitors. By unsoldering all terminals at the same time the part can be removed with little chance of breaking the printed-circuit board.
- Always disconnect the chassis from the power line when soldering. Turning the power switch OFF is not enough. Power-line leakage paths, through the heating element, can destroy transistors.

Transistors—Never attempt to do any work on the transistor amplifiers without first disconnecting the AC-power linecord — wait until the power supply filter-capacitors have discharged.

• **Guard against shorts** — it takes only an instant for a base-to-collector short to destroy that transistor and possibly others direct-coupled to it. [In the time it takes for a dropped machine screw, washer or even the screwdriver, to glance off a pair of socket terminals (or between a terminal and the chassis) a transistor can be ruined.]

- DO NOT bias the base of any transistor to, or near, the same voltage applied to its collector.
- DO NOT use an ohmmeter for testing transistors. The voltage applied through the test probes may be higher than the base-emitter breakdown voltage of the transistor.

Output Stage and Driver—Replacements for output and driver transistors, if necessary, must be made from the same beta group as the original type. The beta group is indicated by a colored dot on the mounting flange of the transistor. Be sure to include this information, when ordering replacement transistors.

• If one output transistor burns out (open or shorts), always remove all output transistors in that channel and check the bias adjustment, the control and other parts in the network with an ohmmeter before inserting a new transistor. All output transistors in one channel will be destroyed if the base-biasing circuit is open on the emitter end.

• When mounting a replacement power transistor be sure the bottom of the flange, the mica insulator and the surface of the heat sink are free of foreign matter. Dust and grit can prevent perfect contact. This reduces heat transfer to the heat sink. Metallic particles can puncture the insulator and cause shorts — ruining the transistor.

• Silicone grease must be used between the transistor and the mica insulator and between the mica and the heat sink for best heat conduction. Heat is the greatest enemy of electronic equipment. It can shorten the life of transistors, capacitors and resistors. (Use Dow-Corning DC-3 or C20194 or equivalent compounds made for power transistor heat conduction.)

• Use care when making connections to speakers and output terminals. Any frayed wire ends can cause shorts that may burn out the output transistors — they are direct-coupled to the speakers. There is no output transformer — nothing to limit current through the transistors except the fuses. To reduce the possibility of shorts at the speakers, lugs should be used on the exposed ends — at least the ends of the stranded wires should be tinned to prevent frayed wire ends. The current in the speakers and output circuitry is quite high. Any poor contact or small-size wire, can cause power losses in the speaker system. Use 14 or 16 AWG for long runs of speaker-connecting wiring.

DC-Voltage Measurements—These basic tests of the transistor circuitry are made without the signal generator. Without any signal input measure the circuit voltages — as indicated on the schematic. The voltage difference between the base and the emitter should be in the millivolt range — a sensitive DC meter is needed for these readings. A low-voltage range of 1 volt, full scale — or lower — is needed.

Audio-Voltage (gain) Measurements—The schematic and printed-circuit board layout diagrams are used. Input signals are injected at the proper points — found most quickly by using layout of the printed-circuit board instead of the schematic. An AUDIO (AC) VTVM connected to the test points should indicate voltages close to those values shown in the boxes on the schematic. Many of the signal levels in the input stages are only a few millivolts — they can not be read on the AC ranges supplied on most Vacuum-Tube AC/DC Volt-ohmmeters (VTVMs). Even with a 1-volt range a signal level of 100 millivolts (.1 volt) will be the first 1/10 of the meter scale. A reading of 1 millivolt (.001 volt) will hardly even move the meter needle.

DIAL STRINGING PROCEDURE

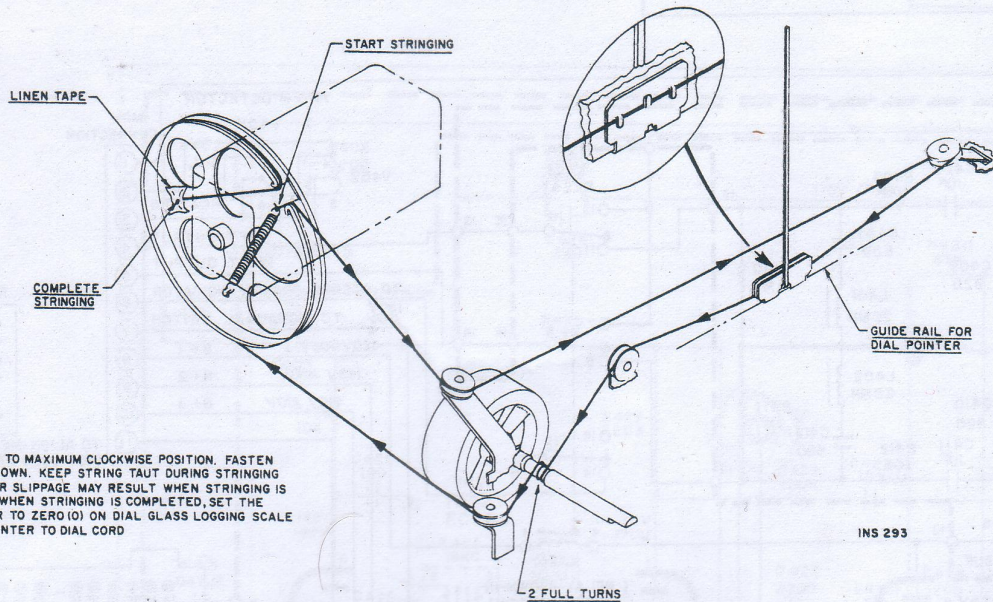

NOTE:
 ROTATE DRUM TO MAXIMUM CLOCKWISE POSITION. FASTEN STRING AS SHOWN. KEEP STRING TAUT DURING STRINGING PROCEDURE OR SLIPPAGE MAY RESULT WHEN STRINGING IS COMPLETED. WHEN STRINGING IS COMPLETED, SET THE DIAL POINTER TO ZERO (0) ON DIAL GLASS LOGGING SCALE AND GLUE POINTER TO DIAL CORD

INS 293

Replacing Dial Lamps

Before replacing the dial lamps, disconnect the power plug from the wall outlet. Proceed as follows:

- Remove all control knobs from their shafts, by pulling them gently away from the control panel.
- Remove the two screws located on the upper right side of the partition which separates the Turntable compartment from the control section.
- Slide the entire control panel (the plate and wood panel to which it is fastened) to the right and upward. The panel can then be lifted off to expose the chassis.
- The lamps, tubular in shape, are held in spring clips at either end of the dial glass, and can be removed by lifting gently.
- Install the new lamp, making sure that the white, painted side faces away from the dial glass. Press the lamp down until it snaps into place.
- Replace the panel by reversing steps above.

Replacement dial lamps can be ordered from Fisher Radio Corporation, Long Island City 1, New York. Please send all requests for parts to the attention of the Parts Department. The part No. is 150441-3.

Replacing Stereo Beacon Lamp

Before replacing the STEREO BEACON lamp, disconnect the power plug from the wall outlet. The lamp assembly is accessible from the rear of the cabinet. It is housed in a white cylinder on the chassis, directly below the dial, and located near the front of the set. Replace the lamp as follows:

- Locate the **white** cylinder described above. Follow the two leads which protrude from the rear of the cylinder to the chassis.
- Slide the clips, located on the other ends of the leads, off the terminal strip contacts by moving them gently away from the chassis.
- Remove the **white** flexible band which secures the bulb leads to the cylinder. Remove the bulb from the cylinder by pulling gently on the leads.
- Place the **new** bulb in the cylinder, and secure it with the flexible band removed in the previous step.
- Slide the clips on the bulb leads over the terminal strip contacts.

Replacement STEREO BEACON lamps can be ordered from Fisher Radio Corporation, Long Island City 1, New York. Please send all requests for parts to the attention of the Parts Department. The part number is 150461-3.

Replacing Fuses

POWER FUSE – To protect against line surges and other adverse conditions sometimes encountered by electronic equipment, the unit is fused at strategic locations. If the unit appears to be inoperative, check to see if the dial lamps light when the Volume control is turned clockwise from the AC OFF position. If the lamps do not light, the unit may have a blown power fuse.

To replace the fuse, which is located in a black receptacle on the lower right-hand side of the Power Amplifier, proceed as follows:

- Turn the Volume control to the AC OFF position.
- Disconnect the power cord from the wall receptacle.
- Push the cap of the fuseholder in, and turn it counterclockwise. The cap will disengage, and you can pull it out, with the fuse remaining in its clip. Replace the fuse with a 3.2-amp Slo-Blo fuse only. Return the cap and fuse to the receptacle, and restore power to the set.

SPEAKER FUSES – If the dial is lit, yet one or both channels of the set does not play, *no matter what program source* (e.g., tuner, turntable, tape recorder, etc.) *is used*, it may be the result of a blown fuse in the output stage of the Power Amplifier. Power transistors could easily be destroyed if the EXTERNAL SPEAKER terminals were accidentally shorted to each other, or to the chassis. To protect the transistors, as well as the speakers, each output stage uses two fuses, which are contained in receptacles labelled FUSES FOR LEFT CHANNEL and FUSES FOR RIGHT CHANNEL. These fuses are precisely rated, and manufactured to function within extremely narrow tolerances. These fuses must be replaced only with fuses rated at 2 amperes. Replacement with any other type of fuse, or with Slo-Blo fuses of the same value may result in damage to the unit, and voids the warranty. If either channel (or both) is inoperative, pull the power plug from the wall receptacle and remove both fuses used in that channel. Simply push the cover of each fuseholder down, rotate it counterclockwise, and lift it from its receptacle. Replace the fuse(s) with a known good fuse (two spare speaker fuses are supplied with your set). Additional fuses are available from your dealer as Fisher part No. F755-145 (2 amp), or from your local radio supplier. Next, plug the set in, and turn it on.

Should distortion become apparent in either channel, replace one of the fuses in that channel as described above. If distortion is still apparent after restoring power to the set, replace the other fuse in the channel with the fuse removed.

Output Stage Balancing and IM Distortion Measurements

● Connect an 8-ohm, 50-watt resistor across the left output terminals. In parallel to the load resistor connect the input leads of an IM (Inter-Modulation) distortion analyzer and the leads of a DC VTVM capable of reading 0.1 volt with accuracy.

● Connect IM-analyzer generator output to the left Monitor input.

● Apply AC power and rotate Volume control to its maximum clockwise position—full volume.

● Increase signal input to amplifier for 20 watts output. (12.5 VAC across 8-ohm load resistor). After one full minute of warm-up time proceed to next step. *The warm-up time is very important (to get proper balance) — the characteristics of the transistors change slightly as their internal temperature rises. A longer warm-up time will not damage the transistors. Once they are warm the tests and adjustments should be completed without delay — before they can cool off.*

● Reduce IM-analyzer generator output for 5 watts output from amplifier (5.16 VAC across load).

● Adjust P1 and P2 (P3 and P4 for right channel) for minimum IM distortion and zero DC voltage across the load. (IM distortion should be less than 0.8% and DC voltage lower than ± 0.1 volts across the 8-ohm load. Use two screwdrivers to adjust the controls—it's faster than shifting from one control to the other.)

● Increase signal input for 40 watts output from amplifier. IM reading should be less than 1% — DC across load should be less than ± 0.3 volt.

REPEAT steps 1 through 7 (above) for right-channel tests.

SEE OUTPUT-STAGE BASE-BIAS CIRCUIT MODIFICATION ON AMPLIFIER SCHEMATIC PAGE.

NOTE—If any of the above instructions are different from those supplied with the IM analyzer instruction manual, it is best to follow those in the manual. If a load resistor of 50-watts rating is built into the IM analyzer, a separate load resistor is not required for the channel under test—one should be wired across the other channel as a precaution. For best results the IM range switch should be set to give a reading in the center to full-scale portion of the meter scale—this gives greater accuracy.

Harmonic Distortion Test

● Connect an audio (sine-wave) generator to the left AUX input. Connect the harmonic-distortion analyzer to the left speaker #1 terminals across an 8-ohm, 50-watt resistive load.

● Apply AC power — rotate Volume control to its maximum clockwise position.

● Set the frequency control of the audio generator to 20 cycles. Adjust the output level for 40 watts (17.9 VAC) across the 8-ohm load. Harmonic distortion should be less than 1%.

REPEAT steps above for right-channel harmonic-distortion measurements.

Stability Test

● Connect audio (sine-wave) generator to the left AUX input. Across the left-speaker terminals connect an 8-ohm, 50-watt load resistor and the vertical-input leads of an oscilloscope.

● Set amplifier controls to positions listed above (control positions).

● Apply AC power—rotate Volume control to its maximum clockwise positions—full volume.

Set the frequency control of the audio generator to 20 cycles. Increase the output level of the audio generator until the sine waves, as viewed on the scope, start to distort—the peaks are clipped from overdriving the amplifier. Check waveforms on scope for instability—changes in wave shape or oscillation (thicker line at a portion of the waveform).

● Repeat the above steps using a 0.1-uf capacitor as a load. Remove the 8-ohm resistor.

REPEAT steps 1 through 5, above, for the right stereo channel.

Transistor Testing

If a power-transistor tester is not available the circuit given below can be used to determine the DC beta of the transistors. This is not a complete test of the transistor.

OPERATION: Connect the transistor to the test circuit. Adjust R2 for a 0.5-ampere reading on M2 in the collector circuit. The DC beta is then calculated

by: $DC\ beta = \frac{\text{reading of } M2}{\text{reading of } M1}$

The DC beta should be between 50 and 250.

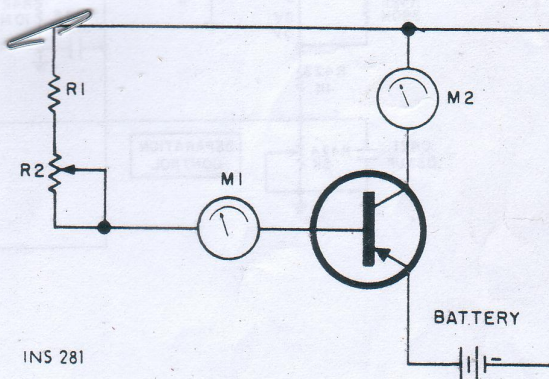

Voltage tests can be made with safety — without ruining transistors — by substituting resistors for the emitter-collector circuit of the power transistors.

Output Stage and Driver—Replacements for output and driver transistors, if necessary, must be made from the same beta group as the original type. The beta group is indicated by a colored dot on the mounting flange of the transistor. Be sure to include this information, when ordering replacement transistors.

If replacement parts are out of stock, locally, they may be obtained directly from the Parts Department of FISHER Radio. They will be shipped "best way", either prepaid or C.O.D. unless otherwise specified.

For instrument-operation information and technical assistance write Richard Hamilton, Customer Service Department, FISHER Radio Long Island City, New York 11101.

1131-1 MULTIPLEX DECODE

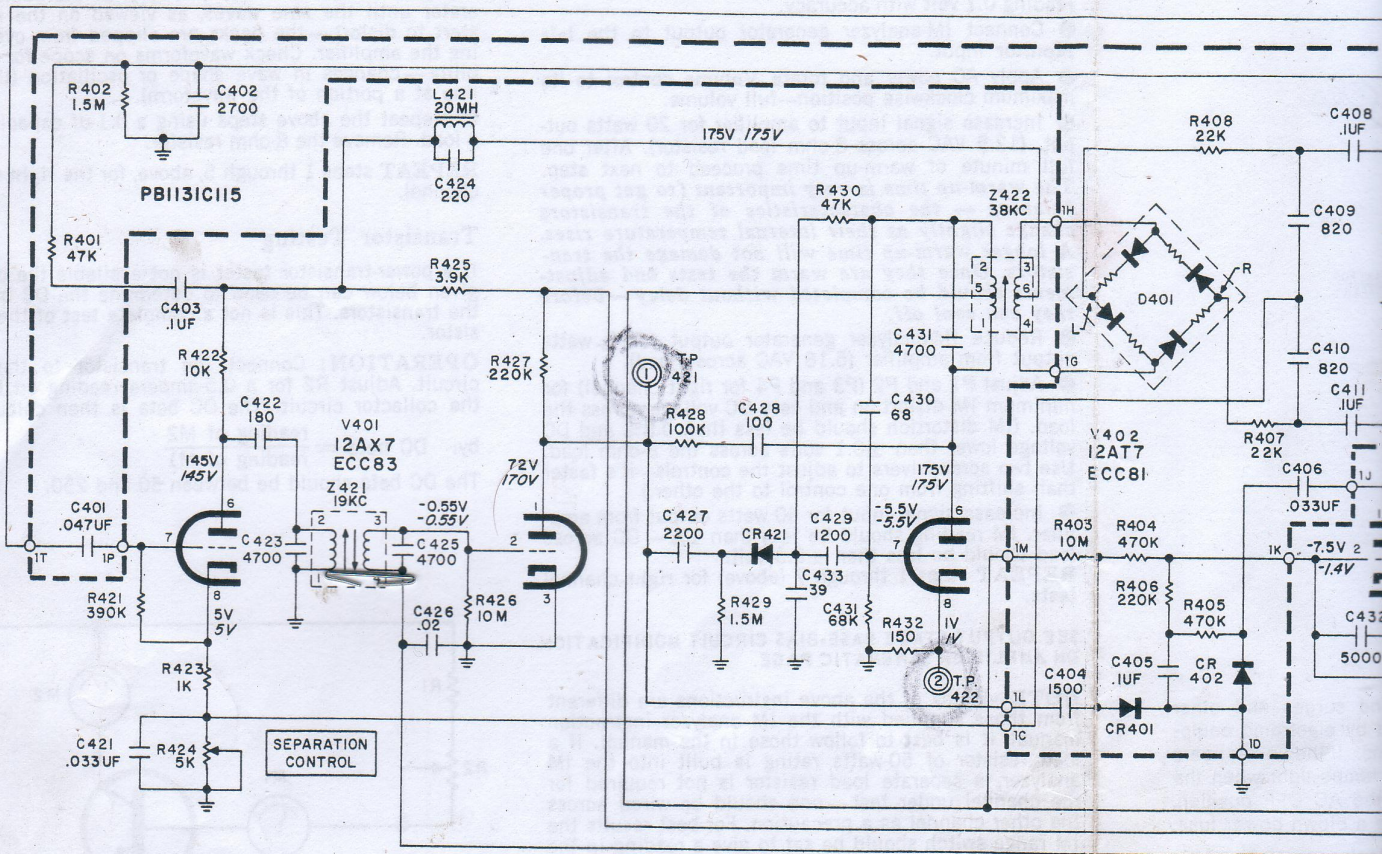

PARTS DESCRIPTION LIST

MULTIPLEX SECTION

All circuit components with symbols beginning with 401 are located on the printed-circuit board; those beginning with 421 are mounted on the metal subchassis.

CAPACITORS

20% tolerance for all fixed capacitors, unless otherwise noted or marked GMV (guaranteed minimum value). All capacitors not marked uF are pF (uF).

Symbol	Description	Part No.
C401	Capacitor, Mylar, .047uF 10% 100V	C50B574-5
C402	Capacitor, Polystyrene, 2700 5% 125V	C50B634-20
C403	Capacitor, Plastic Film, .1uF 20% 250V	C50B633-1
C404	Capacitor, Cer. Disc., 1500, 10%	C50B576-4
C405	Capacitor, Plastic Film, .1uF 20% 250V	C50B633-1
C406	Capacitor, Plastic Film, .033uF 20% 400V	C50B633-20
C407	Capacitor, Cer. Disc., 470 pF 10%	C50B576-1
C408	Capacitor, Plastic Film, .1uF 20% 250V	C50B633-1
C409	Capacitor, Cer. Disc., 820 10%	C50B576-3
C410	Capacitor, Cer. Disc., 820 10%	C50B576-3
C411	Capacitor, Plastic Film, .1uF 20% 250V	C50B633-1

Symbol	Description	Part No.	Symbol	Description	Part No.
C412	Capacitor, Cer. Disc., 470 pF, 10%	C50B576-1	R405	Resistor, Dep. Carbon, 470K, 5%	R12DC473J
C421	Mylar, .033 uF, 10%, 100V	C50574-11	R406	Resistor, Dep. Carbon, 1.5M, 5%	R33DC155J
C422	Polystyrene 180; 5%, 500V	C50634-1	R407	Resistor, Composition, 22M, 10%, 1/2W	RC20BF226K
C423	Polystyrene 4700, 5%, 125V	C50634-21	R408	Resistor, Dep. Carbon, 470K, 5%, 1/8W	R12DC474J
C424	Polystyrene 220, 5%, 500V	C50634-2	R409	Resistor, Dep. Carbon, 470K, 5%, 1/8W	R12DC474J
C425	Polystyrene 4700, 5%, 125V	C50634-21	R410	Resistor, Dep. Carbon, 470K, 5%, 1/8W	R12DC474J
C426	Ceramic, .02uF, 20%, 500V	C50089-5	R411	Resistor, Dep. Carbon, 470K, 5%, 1/8W	R12DC474J
C427	Ceramic, 2200, 20%, 1000V	C50183-10	R412	Resistor, Dep. Carbon, 470K, 5%, 1/8W	R12DC474J
C428	Ceramic, 100, 20%, 1000V	C50183-9			
C429	Ceramic, 1200, 10%, 1000V	C50183-8			
C430	Ceramic, 68, 10%, NPO, 1000V	C50070-46			
C431	Mica, 4700, 5%, 300V	C50332-7			
C432	Ceramic, 5000, 20%, 500V	C50089-1			
C433	Ceramic, 39, 10%, N1500, 1000V	C50070-17			

RESISTORS

Symbol	Description	Part No.	Symbol	Description	Part No.
R401	Resistor, Dep. Carbon, 47K, 5% 1/8W	R12DC473J	R421	Resistor, Dep. Carbon, 47K, 5%, 1/8W	R12DC473J
R402	Resistor, Dep. Carbon, 1.5M, 5% 1/3W	R33DC155J	R422	Resistor, Dep. Carbon, 1.5M, 5%, 1/3W	R33DC155J
R403	Resistor, Composition, 22M, 10%, 1/2W	RC20BF226K	R423	Resistor, Dep. Carbon, 1.5M, 5%, 1/3W	R33DC155J
R404	Resistor, Dep. Carbon, 470K, 5%, 1/8W	R12DC474J	R424	Resistor, Dep. Carbon, 1.5M, 5%, 1/3W	R33DC155J

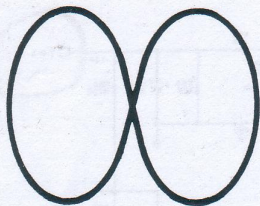

FIGURE 1. Lissajous pattern for MPX Oscillator alignment.

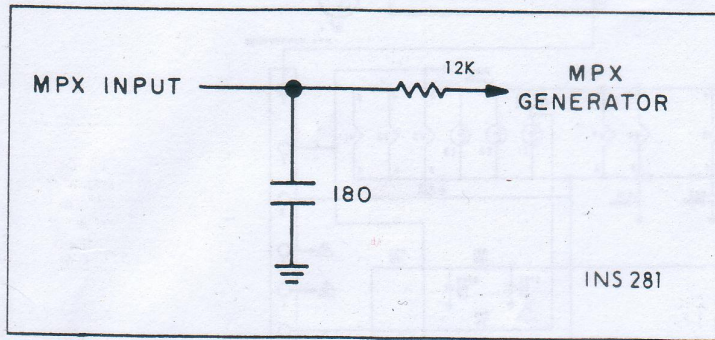
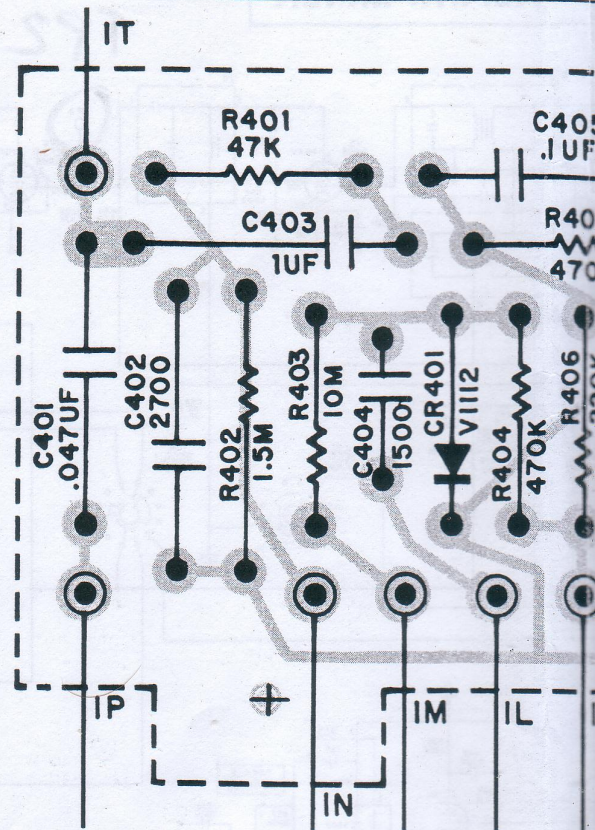

FIGURE 2. Multiplex-alignment coupling network circuit.



ALIGNMENT INSTRUCTIONS

GENERAL

The preferred alignment procedure, in table 1 below, uses a multiplex generator with an RF output, like the FISHER Model 300. Optimum performance will be obtained only when the multiplex decoder is connected to the FM detector with which it will be used. Check IF alignment first—poor alignment can prevent proper multiplex decoder operation.

TEST EQUIPMENT REQUIRED: MULTIPLEX GENERATOR, AUDIO (AC) VTVM, 100 KC OSCILLOSCOPE WITH EXTERNAL SWEEP JACKS, ALIGNMENT TOOL.

TABLE 1

STEPS	GENERATOR		R F DEVIATION	INDICATOR	ALIGNMENT	INDICATION
	CONNECTION	MODULATION		TYPE AND CONNECTION		
1	Multiplex generator RF output to antenna terminals	19 kc pilot only	± 7.5 kc	VTVM to TP 4 21	Z 421 top and bottom	Maximum reading on VTVM
2	19 kc output of generator to oscilloscope horizontal input; generator not connected to MPX section	—	—	Vertical input of oscilloscope to 422 set oscilloscope for external sweep	Z 422	Set frequency of free-running oscillator as close as possible to 38 kc. Lissajous pattern (see figure 1) should be as slow-moving as possible.
3	Same as Step 1	Composite MPX; 1000 cps on left channel only	± 75 kc	VTVM and oscilloscope vertical input to right channel output lug (terminal 1R)	Z 421 top	Maximum reading on VTVM; clean 1000 cps sine wave on oscilloscope
4	Same as Step 1	Composite MPX; 1000 cps on right channel only	± 75 kc	Same as Step 3	MPX separation control (R 424)*	Minimum reading on VTVM should be at least 33 db below reading obtained in Step 3
5	Same as Step 1	Same as Step 4	± 75 kc	VTVM and oscilloscope vertical input to right channel output lug (terminal 1S)	—	Same VTVM reading as obtained in Step 3 ± 2 db; clean 1000 cps sine wave on oscilloscope
6	Same as Step 1	Composite MPX; 1000 cps on left channel only	± 75 kc	Same as Step 5	MPX separation control (R 424), if necessary*	Minimum reading on VTVM should be at least 33 db below reading obtained in Step 5.

* If adjustment is required, adjust for best compromise readings in Steps 4 and 6.

* If adjust

MULTIPLEX DECODER • PRINTED CIRCUIT

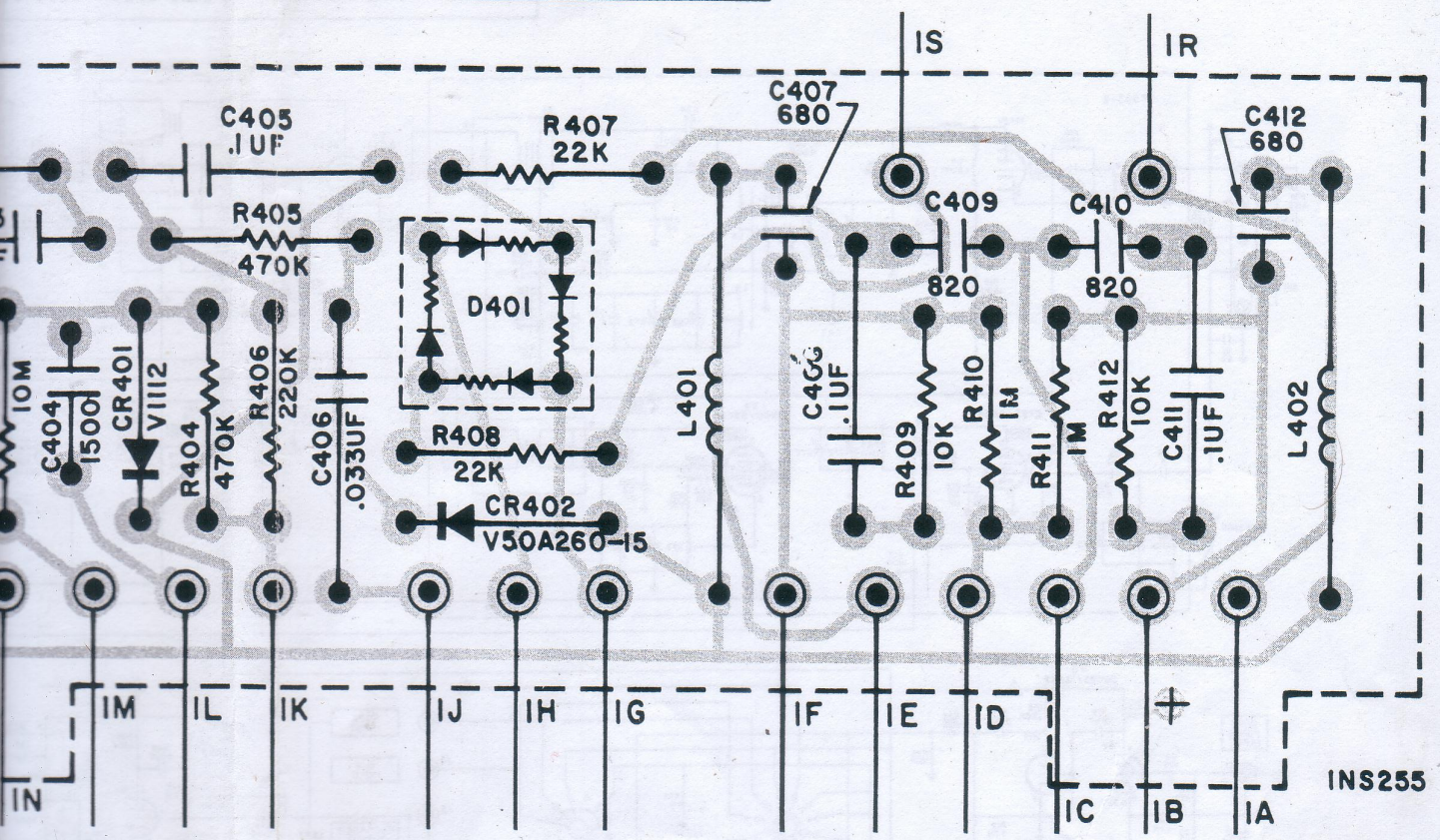

INSTRUCTIONS • MULTIPLEX SECTION

ALTERNATE ALIGNMENT PROCEDURE
 For multiplex generators without an RF output

When using this alignment procedure, it is necessary to disconnect the ratio detector from the multiplex decoder at the point where the generator is connected. Unsolder point 1T carefully. The generator input must be through a simple low-pass filter—a 12 K resistor between the multiplex generator and the MPX input with a 180 pF capacitor from the MPX input end of the resistor to ground (Figure 2).

TEST EQUIPMENT REQUIRED: MULTIPLEX GENERATOR, AUDIO (AC) VTVM, 100 KC OSCILLOSCOPE WITH EXTERNAL SWEEP JACKS, ALIGNMENT TOOL.

TABLE 2

STEPS	GENERATOR			INDICATOR	ALIGNMENT	
	CONNECTION	AUDIO	LEVEL	TYPE AND CONNECTION	ADJUST	INDICATION
1	Composite output of MPX generator to input of MPX demodulator (Point 1)	19 kc pilot only	100 mV RMS (280 MV P-P)	AC VTVM to TP 421	Z 421 top and bottom	Maximum reading on VTVM
2	19 kc output of generator to oscilloscope horizontal input; generator not connected to MPX section	—	—	Oscilloscope vertical input to TP 422	Z 4 22	Set frequency of free-running oscillator as close as possible to 38 kc. Lissajous pattern (see figure 1) should be as slow-moving as possible.
3	Same as Step 1	1000 cps on left channel only	0.7 V RMS (3.92 V P-P)	AC VTVM and oscilloscope vertical input to left channel output lug (terminal 1R)	Z 421 top	Maximum reading on VTVM; clean 1000 cps sine wave on oscilloscope
4	Same as Step 1	1000 cps on right channel only	0.7 V RMS (3.92 V P-P)	Same as Step 3	MPX separation control (R424)	Minimum reading on VTVM should be at least 33 db below reading obtained in Step 3
5	Same as Step 1	Same as Step 4	0.7 V RMS (3.92 V P-P)	VTVM and oscilloscope vertical input to right channel output lug (terminal 1S)	—	Same VTVM reading as obtained in Step 3 ± 2 db; clean 1000 cps sine wave on oscilloscope
6	Same as Step 1	1000 cps on left channel only	0.7 V RMS (3.92 V P-P)	Same as Step 5	MPX separation control (R424), if necessary*	Minimum reading on VTVM should be at least 33 db below reading obtained in Step 5.

* If adjustment is required, adjust for best compromise readings in Steps 4 and 6.

49T TUNER-PREAMPLIFIER

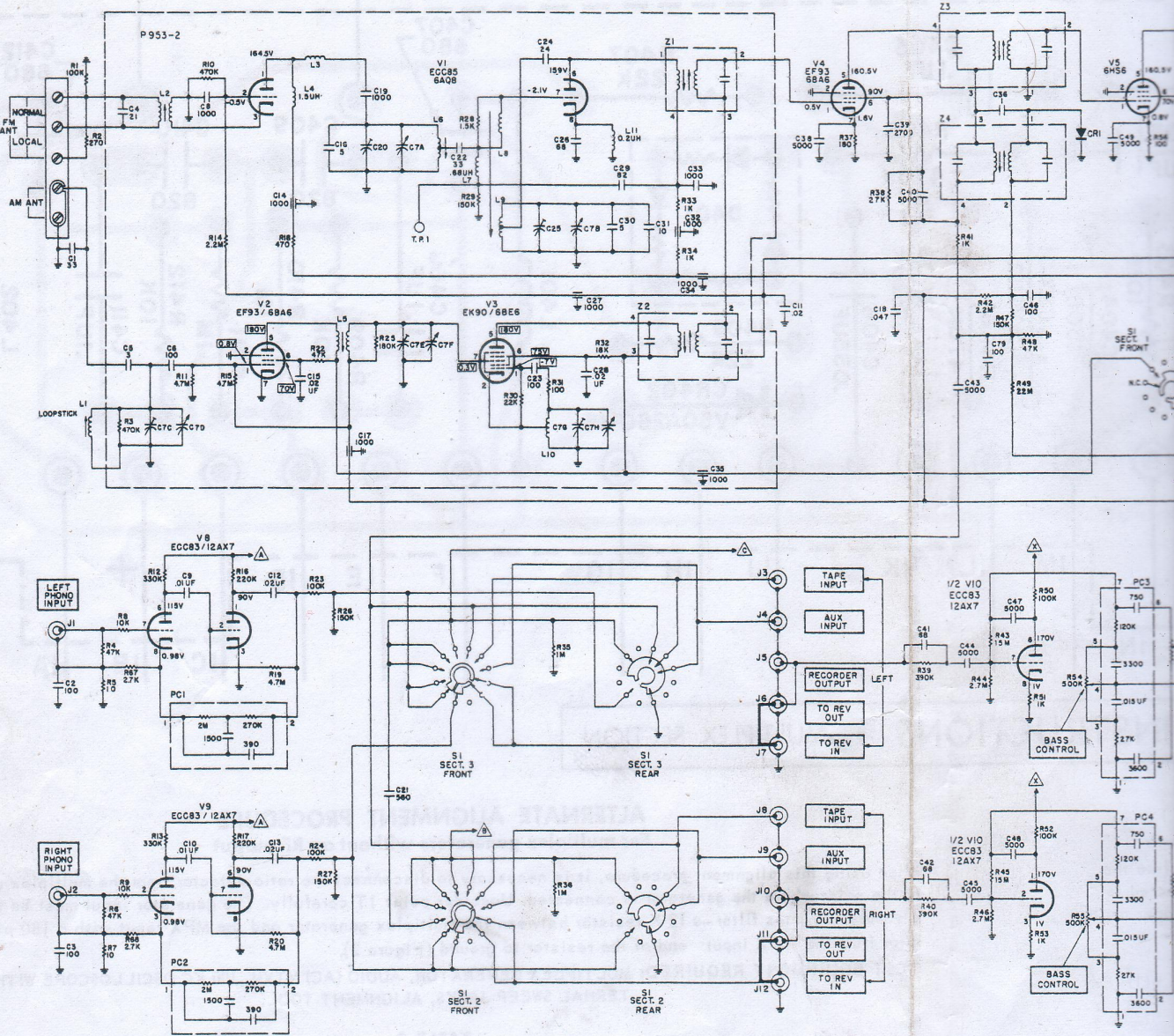

CAPACITORS

10% Tolerance for all fixed capacitors, unless otherwise noted or marked GMV (guaranteed minimum value). All capacitors not marked uF are pF (uF).

Symbol	Description	Part No.			
C1	Ceramic, 33, N750, 1000V	C50070-15	C21	Ceramic, 560, 1000V	C50072-14
C2, 3	Ceramic, 100, GMV, N1500, 1000V	C50070-5	C22	Ceramic, 33, 5%, N750, 1000V	C50070-25
C4	Ceramic, 21, 5%, N750, 1000V	C50070-32	C23	Ceramic, 100, GMV, N1500, 1000V	C50070-5
C5	Ceramic, 3, NPO, 1000V	C50070-28	C24	Ceramic, 24, 5%, N150, 1000V	C50070-8
C6	Ceramic, 100, GMV, N1500, 1000V	C50070-5	C25	Ceramic, Trimmer	C662-123
C7A-H	Variable, Tuning FM/AM	C953-115	C26	Ceramic, 68, 5%, N750, 1000V	C50070-35
C8	Ceramic, 1000, GMV, 500V	C50089-2	C27	Ceramic, Feedthru, 1000, GMV	C592-187
C9, 10	Ceramic, .01uF, 20%, 500V	C50089-3	C28	Ceramic, .02uF, +89-20%, 500V	C50089-4
C11	Ceramic, .02uF +80-20%, 500V	C50089-4	C29	Ceramic, 82, 5%, N1500, 1000V	C50070-30
C12, 13	Ceramic, .02uF, 20%, 500V	C50089-5	C30	Ceramic, 5, ±.5pF, N150, 500V	CC20PJ050D5
C14	Ceramic, Feedthru 1000, GMV	C592-187	C31	Ceramic, 10, ±.5pF, NPO, 500V	CC20CJ100D5
C15	Ceramic, .02uF, +80-20%, 500V	C50089-4	C32, 33		
C16	Ceramic, 5, ±.5pF NPO 500V	C592-187	C34, 35	Ceramic, Feedthru, 1000, GMV	C592-187
C17	Ceramic, Feedthru, 1000, GMV	C592-187	C36	Ceramic, 1, 20%, P100, 1000V	C50070-1
C18	Mylar, .047, 250V	C50197-52	C37	- Deleted -	
C19	Ceramic, 1000, GMV, 500V	C50089-2	C38	Ceramic, 5000, +80-20%, 500V	C50089-6
C20	Ceramic, Trimmer	C662-123	C39	Ceramic, 2700, 1000V	C50072-17
			C40	Ceramic, 5000, +80-20%, 500V	C50089-6
			C41, 42	Ceramic, 68, N2200, 1000V	C50070-12
			C43	Ceramic, 5000, +80-20%, 500V	C50089-6
			C44, 45	Ceramic, 5000, 20%, 500V	C50089-1
			C46	Ceramic, 100, N1500, 1000V	C50070-6
			C47, 48	Ceramic, 5000, 20%, 500V	C50089-1
			C49	Ceramic, 5000, +80-20%, 500V	C50089-6
					C50
					C51
					C52
					C53
					C54
					C55, 56
					C57, 58,
					59, 60
					- Deleted -
					C61
					C62
					C63
					C64
					C65
					C66
					C67, 68, 69
					C70, 71
					C72
					C73
					- Deleted -
					C74
					Electroly
					A-60uF,
					B-60uF,
					C-20uF,
					D-40uF,
					C75

-PREAMPLIFIER

TP2

TP3

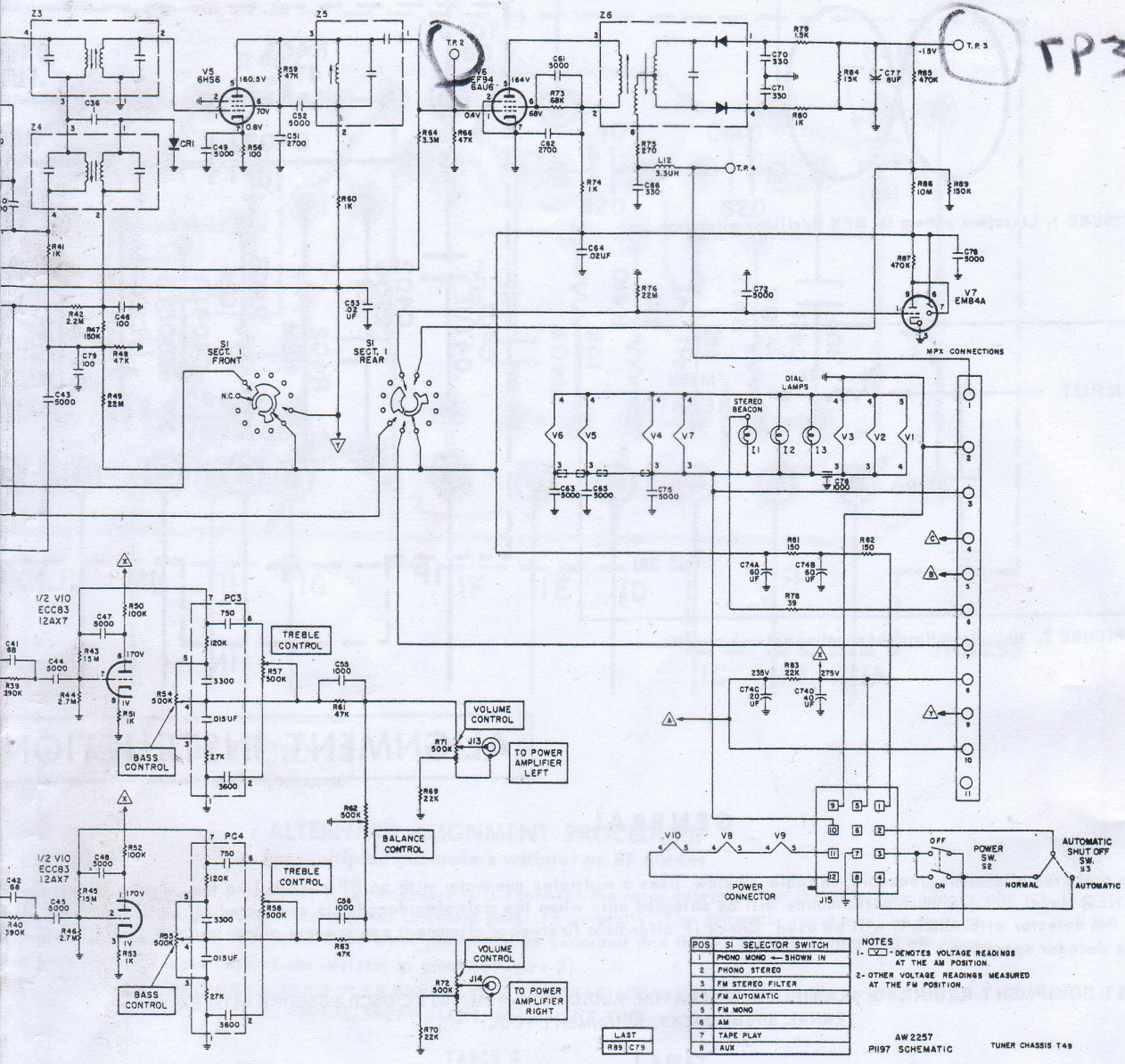

LAST
R99 C79

POS	SI SELECTOR SWITCH
1	PHONO MONO ← SHOWN IN
2	PHONO STEREO
3	FM STEREO FILTER
4	FM AUTOMATIC
5	FM MONO
6	AM
7	TAPE PLAY
8	AUX

NOTES
 1- \square DENOTES VOLTAGE READINGS AT THE AM POSITION.
 2- OTHER VOLTAGE READINGS MEASURED AT THE FM POSITION.

AW 2257
 PI197 SCHEMATIC
 TUNER CHASSIS T48

- C50 - Deleted -
- C51 Ceramic, 2700, 1000V
- C52 Ceramic, 5000, +80-20%, 500V
- C53 Ceramic, .02uF, GMV, 1000V
- C54 - Deleted -
- C55, 56 Ceramic, 1000, 1000V
- C57, 58, 59, 60 - Deleted -
- C61 Ceramic, 5000, +80-20%, 500V
- C62 Ceramic, 2700, 1000V
- C63 Ceramic, 5000, +80-20%, 500V
- C64 Ceramic, .02uF, GMV, 1000V
- C65 Ceramic, 5000, +80-20%, 500V
- C66 Ceramic, 330, 1000V
- C67, 68, 69 - Deleted -
- C70, 71 Ceramic, 330, 1000V
- C72 Ceramic, 5000, +80-20%, 500V
- C73 - Deleted -
- C74 Electrolytic, 4 Section
 A-60uF, 200V
 B-60uF, 200V
 C-20uF, 300V
 D-40uF, 350V
- C75 Ceramic, 5000, +80-20%, 500V

- C50072-17
- C50089-6
- C50071-6
- C50072-3
- C50089-6
- C50072-17
- C50089-6
- C50071-6
- C50089-6
- C50072-1
- C50089-6
- C50180-65
- C50089-6
- C629-138
- C50089-6
- C50070-5

RESISTORS AND POTENTIOMETERS

Deposited Carbon in ohms, 5% Tolerance, 1/8 watt unless otherwise noted K=Kilohm, M=Megohm.

Symbol	Description	Part No.
R1	Composition 100K, 10%, 1/2W	RC20BF104K
R2	Composition, 270, 10%, 1/2W	FC20BF271K
R3	470K, 5%, 1/3W	R33DC474J
R4	47K	R12DC473J
R5	10	R12DC100J
R6	47K	R12DC473J
R7	10	R12DC100J
R8, 9	10K	R12DC103J
R10	Composition, 470K, 10%, 1/2W	RC20BF474K
R11	4.7M, 5%, 1/3W	R33DC475J
R12, 13	Glass, 330K, 5%, 1W	R30G334J

49T TUNER-PREAMPLIFIER (Continued)

R14	2.2M, 5%, 1/3W	R33DC225J	R53	1K, 5%, 1/3W	R33DC102J
R15	4.7M, 5%, 1/3W	R33DC475J	R54, 55	Potentiometer, Dual 500K Bass	R5016B163
R16, 17	220K, 5%, 1/3W	R33DC224J	R56	Composition, 100, 10%, 1/2W	RC20BF101K
R18	Composition, 470, 10%, 1/2W	RC20BF471K	R57, 58	Potentiometer, Dual 500K Treble	R50160B163
R19, 20	4.7M, 5%, 1/3W	R33DC475J	R59	Composition, 47K, 10%, 1/2W	RC20BF473K
R21	- Deleted -		R60	Composition, 1K, 10%, 1/2W	RC20BF102K
R22	Composition, 47K, 10%, 1/2W	RC20BF473J	R61	47K	R12DC473K
R23, 24	100K	R12DC104J	R62	Potentiometer, 500K, Balance	R50160B164
R25	180K, 5%, 1/3W	R33DC184J	R63	47K	R12DC473K
R26, 27	150K	R12DC154J	R64	3.3M, 5%, 1/3W	R33DC335J
R28	Composition, 1.5K, 10%, 1/2W	RC20BF152K	R65	- Deleted -	
R29	Composition, 150K, 10%, 1/2W	RC20BF154K	R66	47K	R12DC473J
R30	Composition, 22K, 10%, 1/2W	RC20BF223K	R67, 68	Glass, 2.7K, 5%, 1/2W	R20G272J
R31	Composition, 100, 10%, 1/2W	RC20BF101K	R69, 70	22K	R12DC223J
R32	Composition, 18K, 10%, 1W	RC30BF183K	R71, 72	Potentiometer, Dual, 500K, Volume	R50160B162
R33, 34	Composition, 1K, 10%, 1/2W	RC20BF102K	R73	Composition, 68K, 10%, 1/2W	RC20BF683K
R35, 36	1M	R12DC105J	R74	Composition, 1K, 10%, 1/2W	RC20BF102K
R37	180	RC20BF181K	R75	Composition, 270, 5%, 1/2W	RC20BF271J
R38	27K	RC20BF273K	R76	Composition, 22M, 10%, 1/2W	RC20BF226K
R39, 40	390K	R12DC394K	R77	- Deleted -	
R41	Composition, 1000, 10%, 1/2W	RC20BF102K	R78	Composition, 39, 10%, 1/2W	RC20BF390K
R42	2.2M, 5%, 1/3W	R33DC225J	R79	Composition, 1500, 5%, 1/2W	RC20BF152J
R43	Composition, 15M, 10%, 1/2W	RC20BF156K	R80	Composition, 1000, 5%, 1/2W	RC20BF102J
R44	2.7M, 5%, 1/3W	R33DC275J	R81, 82	Glass, 150, 10%, 3W	RPG3W151K
R45	Composition, 15M, 10%, 1/2W	RC20BF156K	R83	Composition, 22K, 10%, 1/2W	RC20BF223K
R46	2.7M, 5%, 1/3W	R33DC275J	R84	Composition, 15K, 10%, 1/2W	RC20BF153K
R47	150K	R12DC154J	R85	470K	R12DC474J
R48	47K, 5%, 1/3W	R33DC473J	R86	Composition, 10M, 10%, 1/2W	RC20BF106K
R49	Composition, 22M, 10%, 1/2W	RC20BF226K	R87	470K	R12DC474J
R50	100K, 5%, 1/3W	R33DC104J	R88	- Deleted -	
R51	1K, 5%, 1/3W	R33DC102J	R89	150K	R12DC154J
R52	100K, 5%, 1/3W	R33DC104J	R90	Composition, 3.3, 10%, 1/2W	RC20BF3R3K

MISCELLANEOUS

CR1	Diode	V1112	PC1, 2	Printed Circuit Phono Equalization	PC50187-12
I1	Lamp, Stereo Beacon	I50461-3	PC3, 4	Printed Circuit Tone Control	PC50187-9
I2, 3	Lamps, Dial	I50441-3	S1	Switch, Selector	S1197-114
L1	Loopstick (AM Antenna)	L50210-36	S2	Switch, Power	PART OF R71, 72
L2	Coil, FM Antenna	L818-113	S3	Switch, Automatic Shut-Off	S1197-115
L3	Choke, R. F.	L629-180	S4	Switch, Speakers	S1197-112
L4	Choke, 1.5 Microhenry	L50066-4	Z1	Transformer, FM IF	ZZ662-117
L5	Coil, AM R. F.	L50210-35	Z2	Transformer, AM IF	ZZ2984
L6	Coil, FM R. F.	L953-119	Z3	Transformer, FM IF	ZZ2987
L7	Choke, .68 Microhenry	L50066-1	Z4	Transformer, AM IF	ZZ2984
L8, 9	Coil, FM Oscillator	AS953-116	Z5	Coil, FM Limiter	ZZ50210-6
L10	Coil, AM Oscillator	L50210-28	Z6	Transformer, FM Ratio Detector	ZZ50210-9
L11	Choke, .2 Microhenry	L50066-21	-	Dial Glass Screened	N1197-107
L12	Choke, 3.3 Microhenry	L50066-8	-	Stereo Beacon Lampholder	E946-175-1

49A AMPLIFIER • PARTS DESCRIPTION LIST

CAPACITORS

Symbol	Description	Part No.
C1, 2	Mylar, .022uF, 250V	C50197-49
C3, 4	Electrolytic, 100uF, 15V	C50483-5
C5, 6	Ceramic, 24pF, 5%, N150, 1000V	C50070-8
C7, 8	Electrolytic, 20uF, 250V	C50475-3
C9, 10	Electrolytic, 16uF, 10V	C50483-10
C11, 12, 13, 14	- Deleted -	
C15, 16	Ceramic, 560pF, 10%, 1000V	C50072-14
C17, 18	Ceramic, 330pF, 10%, 1000V	C50072-1
C19	Electrolytic, 4uF, 350V	C50475-4

C20	Electrolytic, 4 section A-40uF, 400V B-40uF, 400V C-40uF, 400V D-60uF, 200V	C50180-63
C21, 22	Electrolytic, 200uF, 35V	C50483-7
C23	Electrolytic, 3000uF, 35V	C50180-61DX
C24	Mylar, .01uF, 250V	C50197-48
C25	Electrolytic, 100uF, 200V	C50475-2
C26, 27	Molded .01uF, 600V	C2747
C28	Electrolytic, 3000uF, 35V	C50180-61DX
C29	Electrolytic, 100uF, 200V	C50475-2
C30, 31	Ceramic, 16pF, 10%, N75, 1000V	C50070-21
C32, 33	Mylar, 0.33uF, 20%, 250V	C50B575-6

RESISTORS AND POTENTIOMETERS

Deposited Carbon in ohms, 5% Tolerance, 1/8 watt unless otherwise noted. K=Kilohms, M=Megohms.

Symbol	Description	Part No.	Symbol	Description	Part No.
R1, 2	1M	R12DC105J	R11, 12	1K	R12DC102J
R3	220K, 5%, 1/3W	R33DC224J	R13A, B	Wirewound, 6.8K, 10%, 7W	RPG7W682K
R4	1.8K	R12DC182J	R14	- Deleted -	
R5	82	R12DC820J	R15, 16	1.8K	R12DC182J
R6	220K, 5%, 1/3W	R33DC224J	R17, 18	10K	R12DC103J
R7	1.8K	R12DC182J	R19	Composition, 330, 10%, 2W	RC40BF331K
R8	82	R12DC820J	R20, 21	- Deleted -	
R9, 10	22K	R12DC223J	R22	Composition, 330, 10%, 2W	RC40BF331K

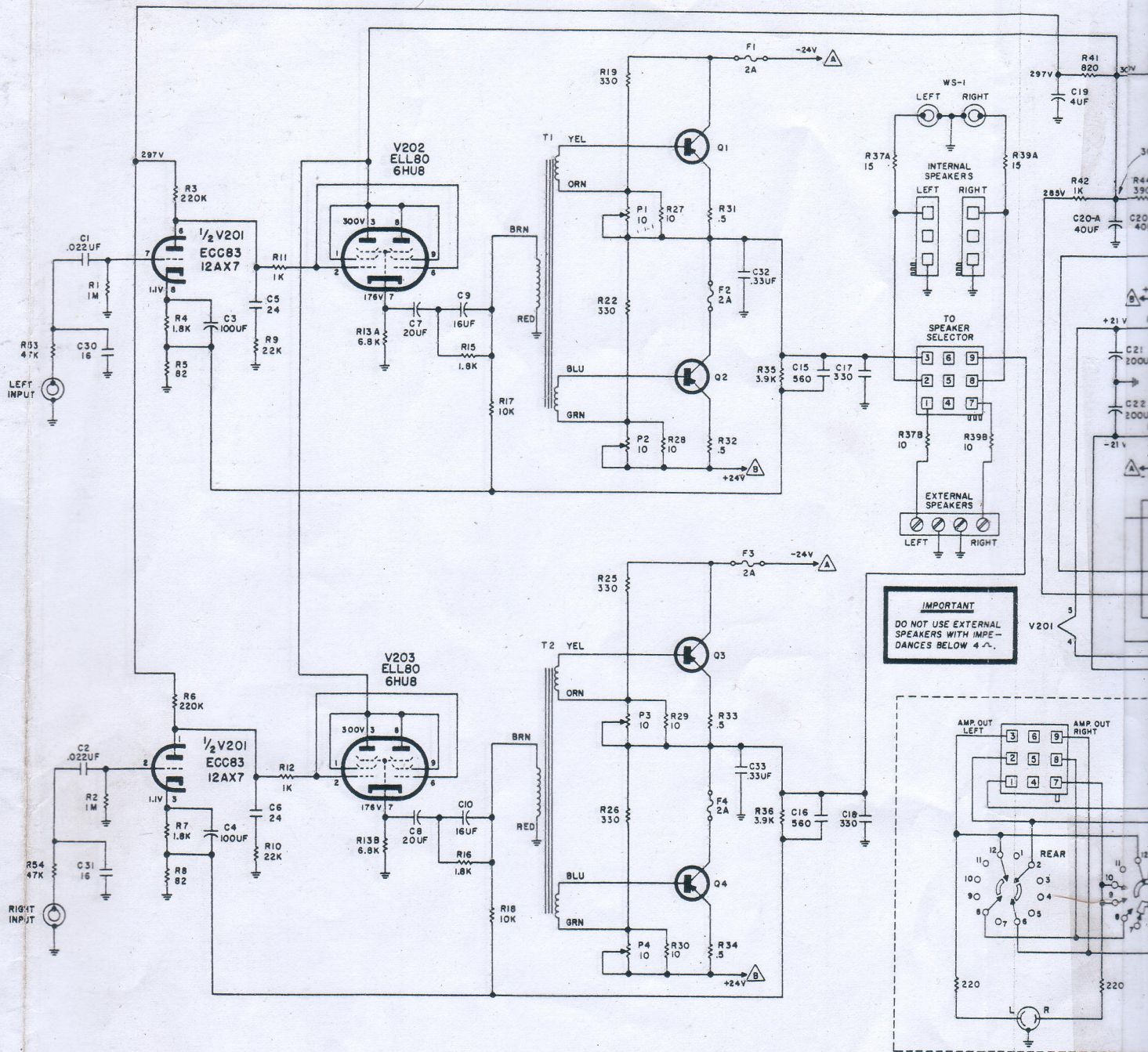

IMPORTANT
DO NOT USE EXTERNAL
SPEAKERS WITH IMPE-
DANCES BELOW 4 Ω.

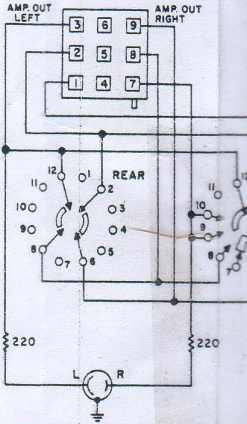

- | | | |
|-------------|-------------------------------------|--------------|
| R23, 24 | - Deleted - | |
| R25, 26 | Composition, 330, 10%, 2W | RC40BF331K |
| R27, 28 | - Deleted - | |
| R29, 30 | Composition, 10, 10%, 1/2W | RC20BF100K |
| R31, 32 | - Deleted - | |
| R33, 34 | Wirewound, .51 ohm, 5%, 2W | RW200WR51J |
| R35, 36 | 3.9K | R12DC392J |
| R37A, B | Wirewound, Dual, 15 + 10, 10%, 10W | R50500-2BX |
| R38 | - Deleted - | |
| R39A, B | Wirewound Dual, 15 + 10, 10%, 10W | R50500-2BX |
| R40 | - Deleted - | |
| R41 | Composition 820, 10%, 1/2W | RC20BF821K |
| R42 | Composition, 1K, 10%, 1/2W | RC20BF102K |
| R43 | 100K | R12DC104J |
| R44 | Wirewound, 390, 10%, 3W | RPG3W391K |
| R45, 46 | Wirewound 22, 5%, 2W | RW200W220J |
| R47 | 100K | R12DC104J |
| R48, 49 | Wirewound, 390, 10%, 3W | RPG3W391K |
| R50 | Wirewound, 150, 10%, 3W | RPG3W151K |
| R51 | Wirewound, 1 ohm, 5%, 3W | RL300W010J |
| R52 | Composition, 820K, 10%, 1/2W | RC20BF824K |
| R53, 54 | 47K | R12DC473J |
| P1, 2, 3, 4 | Potentiometer, W. W. 10 ohm 20%, 2W | R50160-14-LJ |

MISCELLANEOUS

- | | | |
|--------------|-----------------------------|-------------|
| CR1, 2 | Diode, Silicon Rectifier | SR50411-1 |
| CR3, 4, 5, 6 | Diode, Silicon Rectifier | SR50517 |
| F1, 2, 3, 4 | Fuse, 2 Ampere | F755-145 |
| F5 | Fuse, 3.2 Ampere, Slo-Blo | F33319 |
| Q1, 2, 3, 4 | * Transistor, Power, 35144 | *TR35144 |
| T1 | Transformer, Driver (left) | T1135-116-1 |
| T2 | Transformer, Driver (right) | T1135-116-2 |
| T3 | Transformer, Power | T1135-115 |
- * Transistor must be replaced with one from same Beta group, as indicated by the color dot on the transistor, unless both transistors are replaced with a matched pair. (Always replace mica insulator when replacing transistor.)

OUTPUT-STAGE BASE-BIAS CIRCUIT MODIFICATION

The critical adjustment of the base-bias adjusting potentiometers (P1, P2, P3, P4—in the main schematic) is eliminated by replacing the controls with voltage-and-temperature compensating diodes. These diodes will keep the base-bias voltage within ±0.015 volt of the selected value even when

the supply voltage varies with temperature variations (+158°F). WHENEVER MODIFICATION SHOULD BE MADE FOR THIS CIRCUIT IN ANY UNIT made for both the right and left channels:

- Remove the 10-ohm potentiometer (P2, P3, P4).
- Remove the 10-ohm, 10% resistor (R28, R29, R30).
- Remove the 0.5-ohm resistor connected to the emitter of the output transistors.
- Install a 0.75-ohm, 5% resistor (part number RL300W units removed from the original design).
- Install the diodes (F1, F2, F3, F4) in place of the 10-ohm potentiometers. Make sure the correct polarity is observed (red dot on the diode side in the schematic indicates the correct polarity).

49A AMPLIFIER

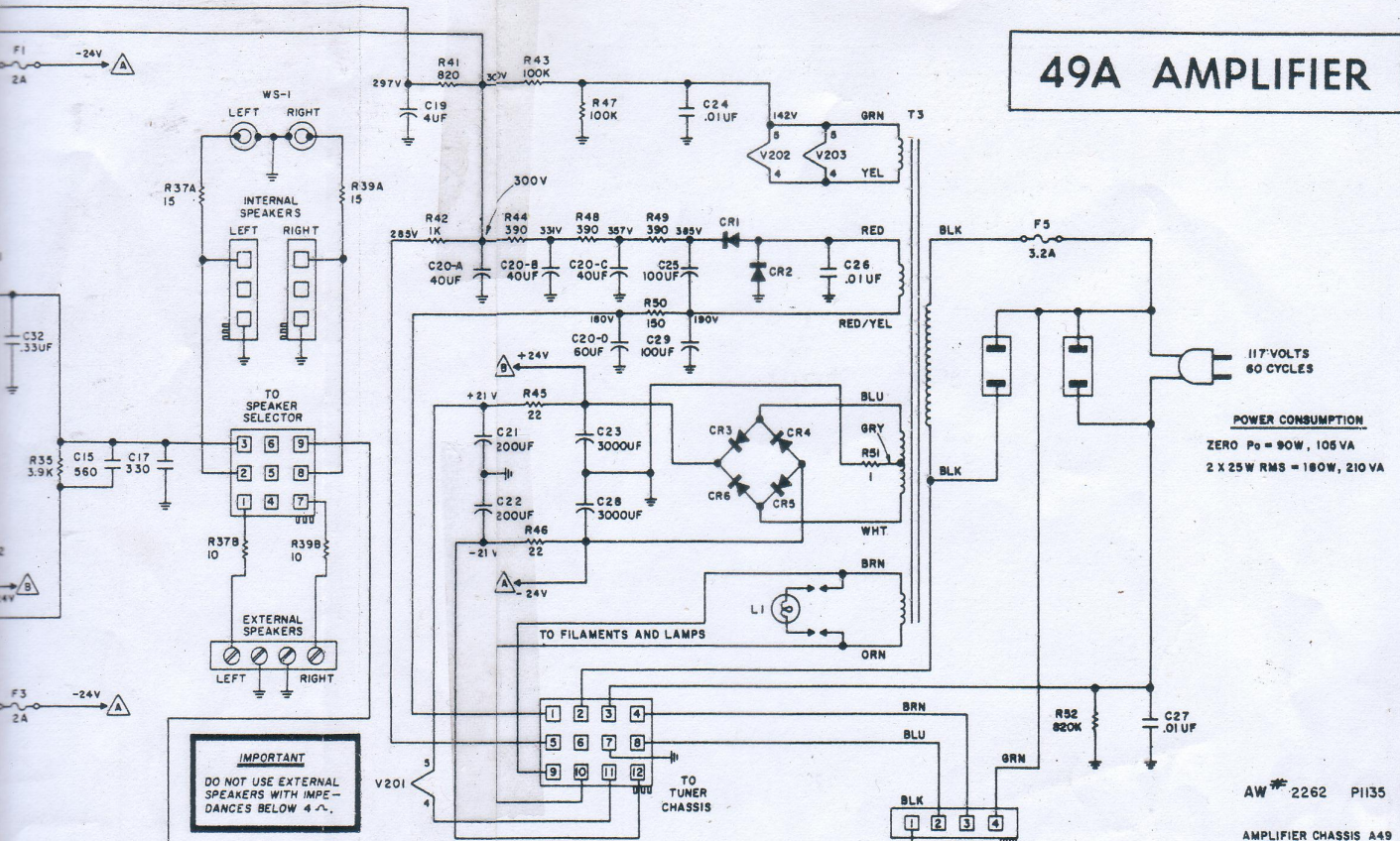

POWER CONSUMPTION
 ZERO P_o = 90W, 105VA
 2 X 25W RMS = 180W, 210VA

AW# 2262 P135 SCHEMATIC
 AMPLIFIER CHASSIS A49

IMPORTANT
 DO NOT USE EXTERNAL SPEAKERS WITH IMPEDANCES BELOW 4Ω.

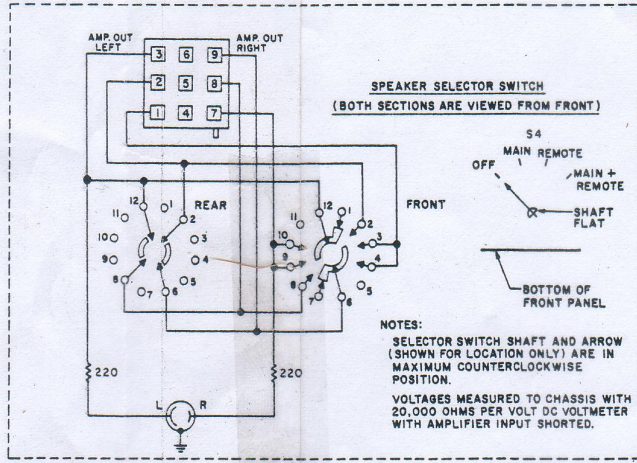

NOTES:
 SELECTOR SWITCH SHAFT AND ARROW (SHOWN FOR LOCATION ONLY) ARE IN MAXIMUM COUNTERCLOCKWISE POSITION.
 VOLTAGES MEASURED TO CHASSIS WITH 20,000 OHMS PER VOLT DC VOLTMETER WITH AMPLIFIER INPUT SHORTED.

LAST
 R54 C37

ILLANEOUS

ectifier
 rifier
 Slo-Blo
 35144
 ver (left)
 ver (right)
 ver

with one from same Beta group,
 on the transistor, unless both
 with a matched pair. (Always re-
 replacing transistor.)

- SR50411-1
- SR50517
- F755-145
- F33319
- *TR35144
- T1135-116-1
- T1135-116-2
- T1135-115

the supply voltage varies as much as $\pm 40\%$ or with chassis-temperature variations between -20°C (0°F) and $+70^{\circ}\text{C}$ ($+158^{\circ}\text{F}$). WHENEVER POSSIBLE THIS CIRCUIT MODIFICATION SHOULD BE MADE TO ALL CHASSIS NOT WIRED FOR THIS CIRCUIT IMPROVEMENT. Modification *must* be made for both the right and left channels.

- Remove the 10-ohm bias-adjusting potentiometers (P1, P2, P3, P4).
- Remove the 10-ohm, 1/2-watt, composition resistors (R27, R28, R29, R30).
- Remove the 0.5-ohm resistors (R31, R32, R33, R34) connected to the emitters of Q1, Q2, Q3 and Q4.
- Install a 0.75-ohm, 5%, 3-watt, wirewound resistor (FISHER part number RL300W075S) in place of each of the 0.5-ohm units removed from the power-output transistor emitters.
- Install the diodes (FISHER part number GET50825-1) in place of the 10-ohm composition resistors - observe diode polarity. Make sure that the diode lead identified by the red dot (on the side of the case) is connected as indicated in the schematic insert.

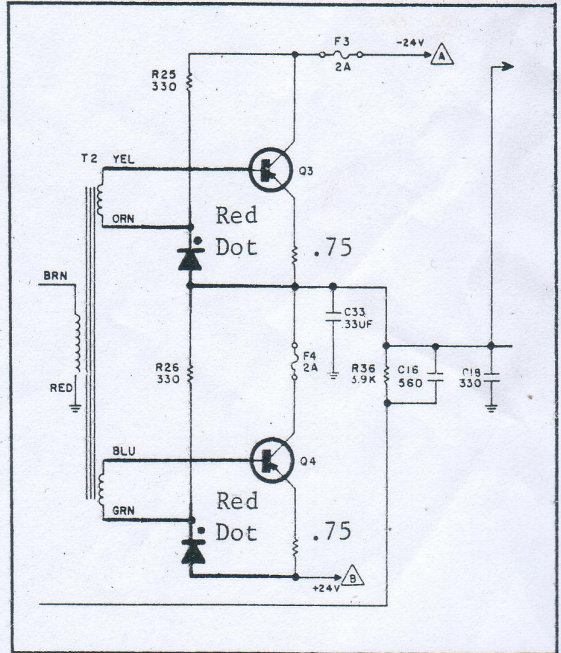

The output-stage base-bias circuit modification is identical for both the left and the right channels - only the part-callout numbers (symbols) are different. The above schematic insert is for the right channel.

TROUBLESHOOTING GUIDE

RE

Does not go on – (pilot or dial lamps do not light) in any position of **SELECTOR** switch.

Check: Fuse F5, the power cord and plug, wall outlet, AUTO SHUTOFF switch S3, Power switch S2, J15 and its plug and interconnecting cable.

Does not go on – (pilot or dial lamps do not light) only in **PHONO** positions of the **SELECTOR** switch.

Check: AUTO SHUTOFF switch S3, J15 and its plug and interconnecting cable, the turntable switch and the changer connector.

Distortion (both channels) in any position of the **SELECTOR** switch.

**Hum or
No audio output**

Pull out plugs in RCRDR (recorder) OUTPUT jacks (J5, J10).
Disconnect reverberation unit from REV IN REV OUT jacks and insert jumpers (a must).

Check: Speaker switch position and its operation Speaker connectors and plugs.
Test (filament leakage for hum) V10, V201 or substitute.
+24 and -24-volt transistor-amplifier power supply (C23, C28, CR3, CR4, CR5, CR6).
+21 and -21-volt DC filament supply for V8, V9, V10 and V201 (C21, C22, R45, R46).

Distortion (LEFT channel only) **SELECTOR** in **PHONO** and **FM** positions.

**Hum or
No audio output**

Remove plug from J5 (LEFT RCRDR OUT)
Remove plugs from J6, J7 (REV IN, REV OUT) and insert jumpers

Check: Plug in J13 and interconnecting cable to amplifier chassis. Position of **BALANCE** control. Q1, Q2 and bias setting (P1 and P2).
Test (filament leakage for hum) V10, V201, V202.

Distortion (RIGHT channel only) **SELECTOR** in **PHONO** and **FM** positions.

**Hum or
No audio output**

Remove plug from J10 (LEFT RCRDR OUT)
Remove plugs from J11, J12 (REV IN, REV OUT) and insert jumper.

Check: Plug in J14 and interconnecting cable to amplifier chassis. Position of **BALANCE** control. Q3, Q4 and bias setting (P3 and P4).

Distortion (LEFT channel only) **SELECTOR** in **PHONO** positions only.

**Hum or
No audio output**

Remove plug from J1 (LEFT PHONO INPUT).
Test (filament leakage for hum) V8 or substitute.

Check: +21, -21-volt power supply (R45, 46, C1, 22).

Distortion (RIGHT channel only) **SELECTOR** in **PHONO** positions only.

**Hum or
No audio output**

Remove plug from J2 (RIGHT PHONO INPUT).
Test (filament leakage for hum) V9 or substitute.

Check: +21, -21-volt supply (R45, 46, C21, 22).

Distortion (both channels) **FM** only – **SELECTOR** in **MONO** and **AUTO** positions.

**Hum or
No audio output**

Tune to other stations.

Check: Antenna position and connections, Relay K421 and detector alignment.
Test (filament leakage for hum) V1, V2, V3, V4, V5, V6, V401.

Distortion (both channels) **FM** **AUTO** position of **SELECTOR** ONLY.

**Hum or
No audio output**

Tune to other stations.
Try **FM MONO** and **FM STEREO FILTER** positions.

Check: Antenna position and connections. Multiplex decoder (alignment, etc.)
Relay K421 on MPX subchassis.
Test (filament leakage for hum) V401, V402, D401 or substitute.

STEREO BEACON does not work

Check: Relay K421 on MPX subchassis.
Test: V402, CR401, CR402

Distortion **AM** only Tune to other stations.

**Hum or
No audio output**

Check: AM antenna or connect 15 to 20 – feet wire to AM antenna terminal temporarily.
Test (filament leakage for hum) V2, V3, V4 and CR1.

STEPS	SELECTOR
	1
2	AM
3	AM
4	Repe

5	FM
6	FM
7	FM
8	FM
9	Repe

NOTE: For cal

PREFERRED ALIGNMENT PROCEDURE

READ THESE INSTRUCTIONS VERY CAREFULLY BEFORE ATTEMPTING ALIGNMENT

CONTROL POSITIONS:

- Rotate tuning knob to set dial pointer to the zero index mark on logging scale (if the pointer will not go to zero without forcing reset the pointer.)
- Set volume control to minimum (full counterclockwise).
- Disconnect the external antennas and the AM-antenna link.
- Disable the AGC for AM RF alignment – just short across C18 or C80.

FM SIGNAL GENERATOR: Modulated 30% (± 22.5 deviation at 400 cps).

ALIGNMENT PRECAUTIONS:

- The chassis and the test instruments must be warmed up for at least 15 minutes to reduce any possible drift.
- Adjust the AC powerline input for 117 VAC to the chassis (50 to 60 cycle).
- Use only the proper, fully insulated, alignment tools.

AM ALIGNMENT

STEPS	CHASSIS		SIGNAL GENERATOR			INDICATOR		ALIGNMENT	
	SELECTOR	STATION SELECTOR	COUPLING	FREQ.	MOD.	TYPE	CONNECTION	ADJUST	INDICATION
1	AM	Point of no signal and no interference	AM Gen. connected thru .01-uf cap to V2, Pin 1	455 KC	30% AM at 400 cps	AC VTVM	to Left RCRDR Output	Z2, Z4 top and bottom	Maximum voltage
2	AM	600 KC	AM Gen. connected thru 220-uuf cap. to the AM antenna terminal Disconnect link.	600 KC	30% AM at 400 cps	AC VTVM	to Left RCRDR Output	L10, L5 L1	Maximum voltage
3	AM	1400 KC	AM Gen. connected thru 220-uuf cap. to the AM antenna terminal Disconnect link.	1400 KC	30% AM at 400 cps	AC VTVM	to Left RCRDR Output	C7H, C7E C7C	Maximum voltage
4	Repeat steps 2 and 3 for proper dial calibration and maximum output.								

FM ALIGNMENT

5	FM	Point of no signal and no interference	FM Gen. connected to ungrounded tube shield over V1	10.7 MC	None	DC VTVM	to test point 3	Z1, Z3, Z5 and Z6, top & bottom	Maximum negative voltage
6	FM	Point of no signal and no interference	FM Gen. connected to ungrounded tube shield over V1	10.7 MC	None	Connect two 47K ohm resistors in series across C77. Connect a VTVM between the junction of the two 47K ohm resistors and the junction of L12 and C66		Z6 top	Zero reading on zero center scale
7	FM	90 MC	FM Gen. connected thru two 120-ohm carbon resistors (Figure 1) to the FM Normal Antenna terminals	90 MC	30% FM (22.5 KC Dev.) at 400 cps	DC VTVM	to test point 2 and scope to Left RCRDR Output	L9, L6, L2	Check for sinusoidal waveform (Figure 2) and adjust for maximum negative voltage.
8	FM	106 MC	FM Gen. connected thru two 120-ohm carbon resistors (Figure 1) to the FM Normal Antenna terminals	106 MC	30% FM (22.5 KC Dev.) at 400 cps	DC VTVM	to test point 2 and scope to Left RCRDR Output	C25 and C20	Check for sinusoidal waveform (Figure 2) and adjust for maximum negative voltage.
9	Repeat steps 7 and 8 at least once for proper dial calibration and maximum output.								
NOTE: For calibrating both the AM and FM, use as low an output voltage as possible from your signal generator.									

POWER OUTPUT MEASUREMENT

The power-output stage of this unit is designed to deliver its full-rated power with program material (voice or music) into 4-to-16-ohm loads for indefinite periods. When a constant audio tone is used as a signal to measure the continuous RMS power output certain precautions must be taken.

- Measure the power output of one channel at a time.
- Limit the measurement period to 10 minutes (with a load resistance between 4 and 16 ohms).

Should it ever be necessary to measure the power output of both channels simultaneously, use a load of 4 or 8 ohms (per channel).

Limit measurement to a period no longer than 1 minute for a 4-ohm load or to 5 minutes for an 8-ohm load.

GNMENT

TUNER CHASSIS LAYOUT

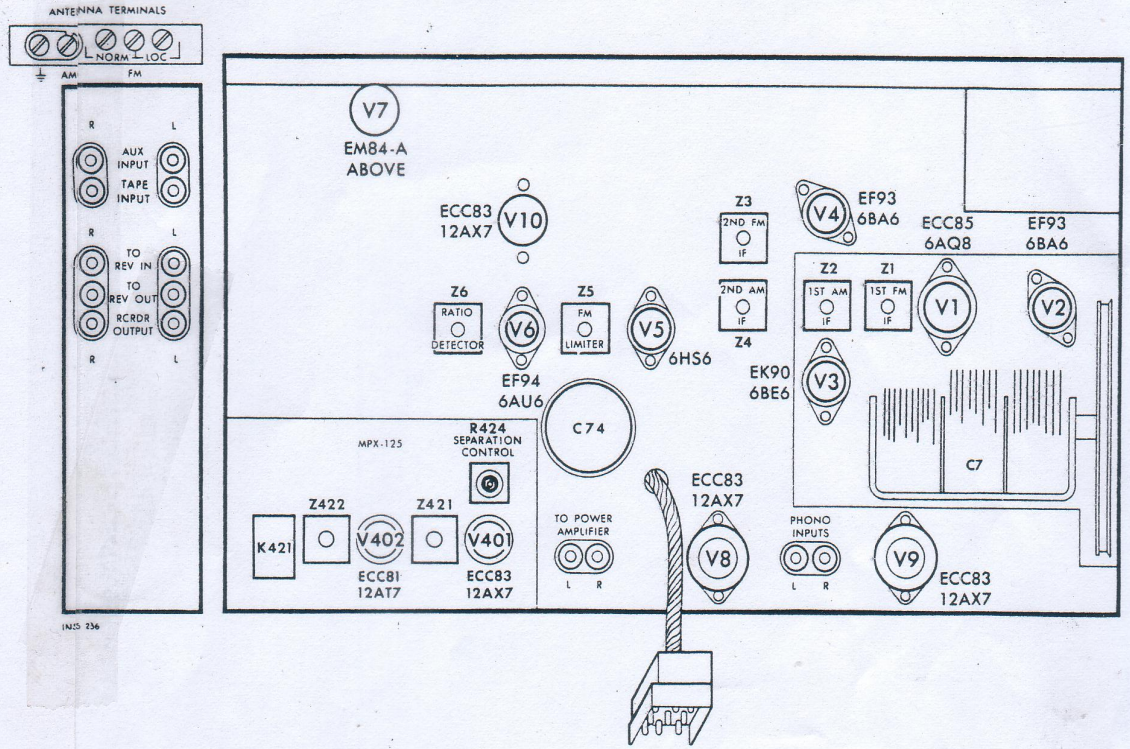

ALIGNMENT	
	INDICATION
	Maximum voltage
	Maximum voltage
	Maximum voltage

POWER AMPLIFIER CHASSIS LAYOUT

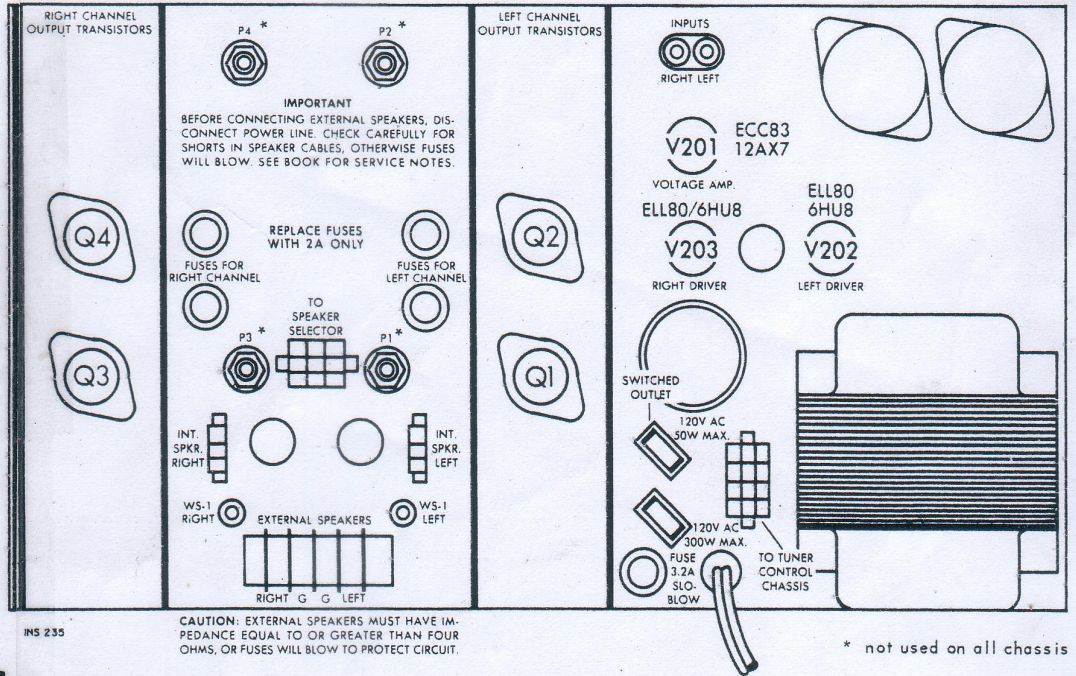

Z5 top m	Maximum negative voltage
	Zero reading on zero center scale
	Check for sinusoidal waveform (Figure 2) and adjust for maximum negative voltage
	Check for sinusoidal waveform (Figure 2) and adjust for maximum negative voltage

CAUTION: EXTERNAL SPEAKERS MUST HAVE IMPEDANCE EQUAL TO OR GREATER THAN FOUR OHMS, OR FUSES WILL BLOW TO PROTECT CIRCUIT.

* not used on all chassis



FISHER RADIO

NEW YORK

